





公司简介

Company profile



董事长
戴丹 先生

Chairman Mr. Dai Dan

企业实景

Huahan Headquarter

大连华韩智能装备有限公司

大连华韩智能装备有限公司是由橡胶行业的顶尖专家组成。我们不仅是世界一流的橡胶硫化厂、橡胶成型设备和橡胶输送带压机制造商，也是领先的橡胶加工行业一站式系统解决方案提供商。我们通过结合广泛的专业知识和能力，开发了几乎所有类型的橡胶机械设备和压机生产线，以满足客户的独特要求，并坚定地保持我们在该行业的领导地位。持续运转的生产线和机械运转的轰鸣声，正是华韩人专业技能和不屈不挠精神的体现。同时也为世界橡胶工业的发展贡献了华韩的力量。

Dalian Huahan Intelligent Equipment Co., Ltd.

Dalian Huahan was established by a group of leading experts in the rubber industry. We are not only a world-class rubber vulcanization machinery, rubber molding equipments and rubber conveyor belt presses manufacturer but also a leading rubber processing industry one-stop system solution provider. We have developed almost all type of equipments and press lines for rubber machinery industry by combining broad expertise and capabilities to meet the customer unique requirements with the strong determination to maintain our leadership in this industry. The ceaselessly operating production lines and the hum of machinery stand as testament to the expertise and tireless efforts of Huahan people, while also contributing Huahan strength to the development of the world's rubber industries.



输送带带坯成型机生产线

Belt Carcass Forming Production Line

设备组成/Equipment Composition

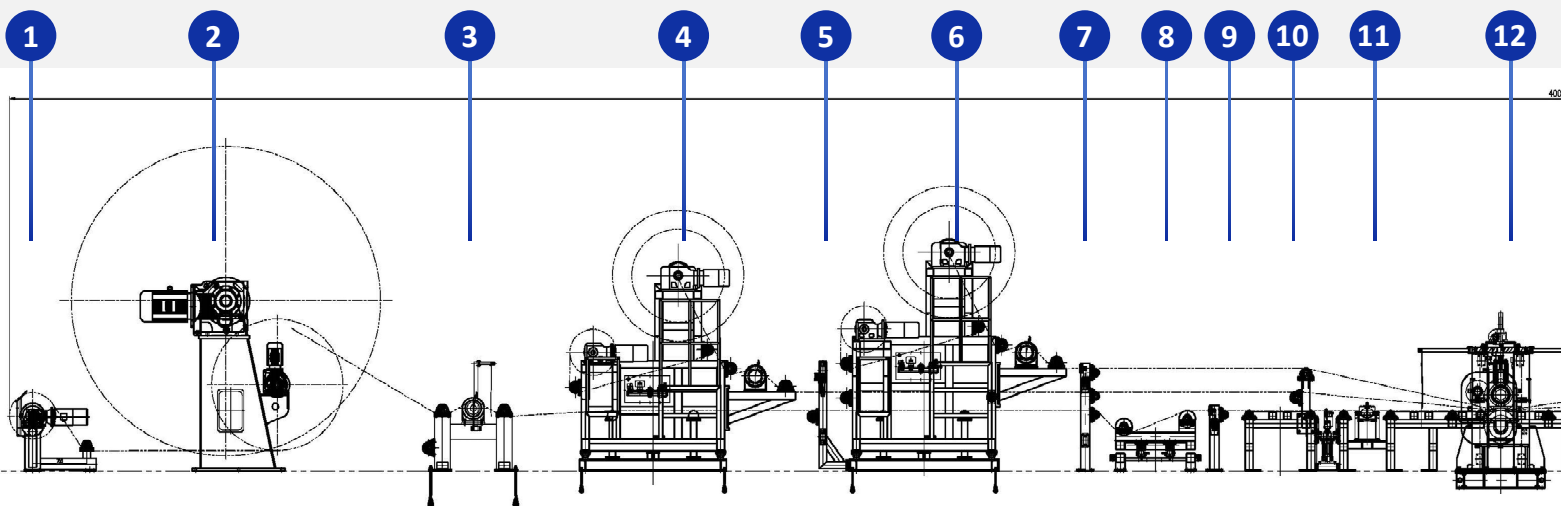

- 1. 垫布导开卷取装置
Liner Cloth Let-off /wind-up Device
- 2. 导开卷取装置
Let-off /wind-up Device Device
- 3. 基带导辊装置
Base Belt Guiding Device
- 4. 材料车
Material Cart
- 5. 侧偏装置
Anti-Lateral Deviation Device
- 6. 材料车
Material Cart
- 7.
- 8.
- 9.
- 10.
- 11.
- 12. 压合牵引机
Pulling and Laminating Machine
- 13. 贴边胶装置
Edge Gluing Device

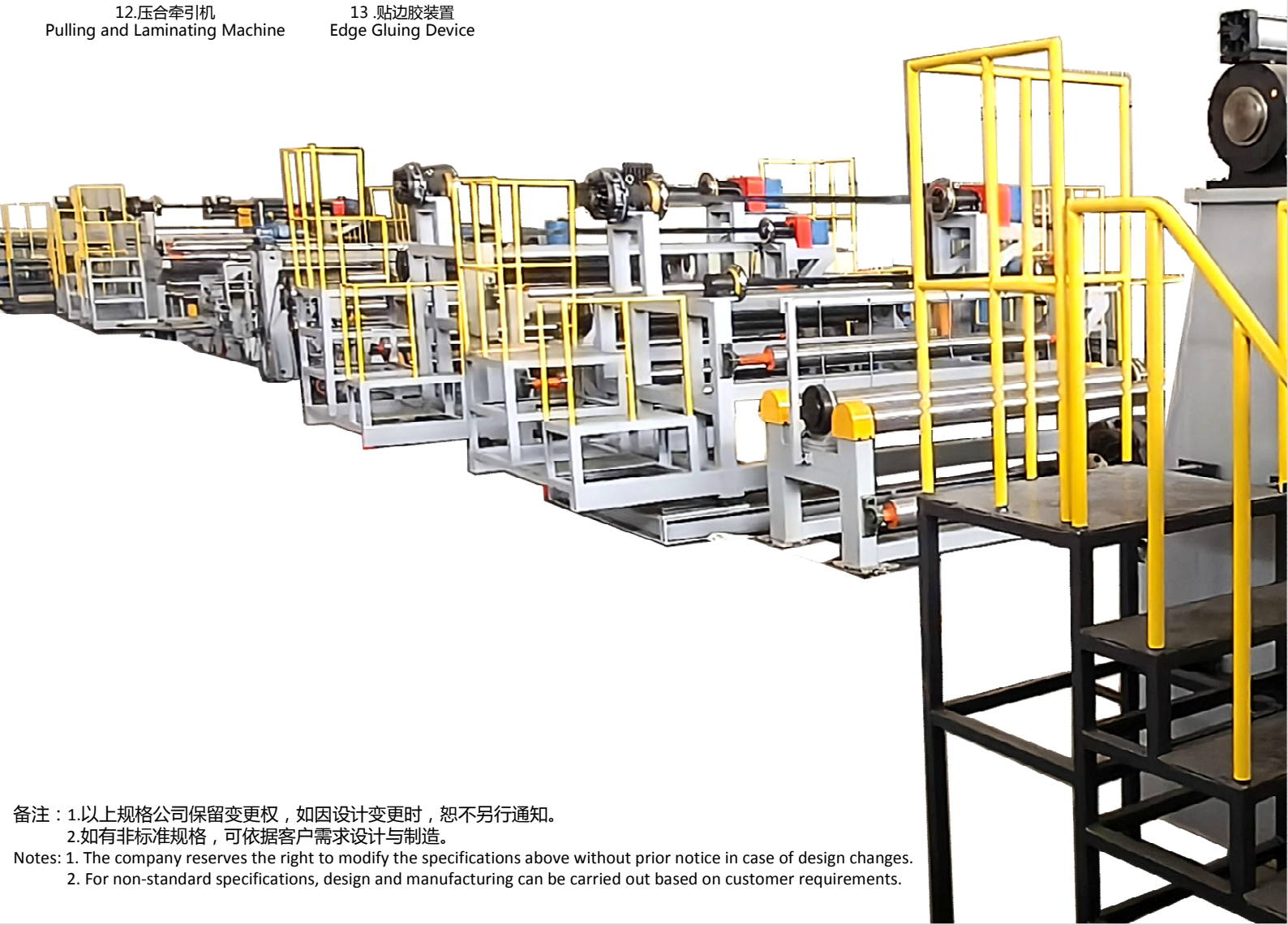

备注：1. 以上规格公司保留变更权，如因设计变更时，恕不另行通知。

2. 如有非标准规格，可依据客户需求设计与制造。

Notes: 1. The company reserves the right to modify the specifications above without prior notice in case of design changes.

2. For non-standard specifications, design and manufacturing can be carried out based on customer requirements.

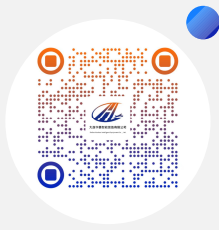

扫码观看
实景设备

Scan to watch the
real-life equipment

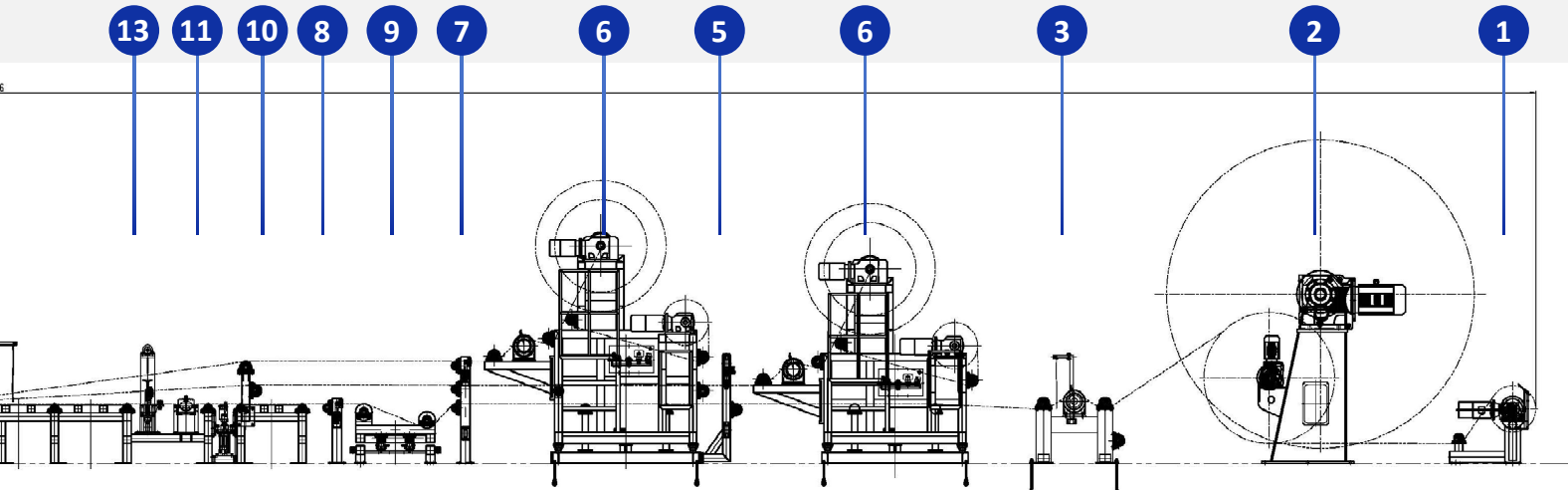

7.侧偏装置
Anti-Lateral Deviation Device

8.基带纠偏装置
Base-belt Anti-Deviation Device

9. 基带侧偏装置 I/II
Base-belt Anti-Lateral Deviation Device

10.切边装置
Trimming edge Device

11. 刷胶浆装置
Glue Coating Device



扫码咨询
Scan to consult



输送带带坯成型机生产线

Belt Carcass Forming Production Line

设备特点/Features

该生产线在成型过程中，带坯在磁粉制动器的控制下，在张力状态下贴合成型，垫布导开和卷取采用平皱装置保证垫布不起皱；成型作业可来回两侧进行；材料车可手动调节宽度方向的位置，在涨紧辊装置就近设置一个急停按钮。转动速度手动控制。全线电机配置在同一侧，垫布卷取辊采用轴辊可分离的形态，该生产线可两头往返进行贴合，涨紧辊处于整条线的中间位置。

During the forming process, the belt blank is adhered under tension control by the magnetic powder brake. The unwinding and winding of the backing cloth are ensured by a flattening device to prevent wrinkling. The forming operation can be performed bidirectionally. The material car allows manual adjustment of the width direction position, with an emergency stop button installed near the tension roller device. The rotation speed is manually controlled. All motors are configured on the same side, and the backing cloth winding roller adopts a separable shaft roller design. The production line can operate bidirectionally at both ends, with the tension roller positioned at the midpoint of the entire line.



技术参数/Specification

参数/型号 Parameter/Model	DCS-1400	DCS-1800	DCS-1800	DCS-2600
成型带坯最大宽度 (mm) Max. Forming Belt Width (mm)	1200	1600	2200	2400
成型带坯最大厚度 (mm) Max. Forming Belt Thickness (mm)	30	30	30	40
成型带坯最大卷径 (mm) Max. Forming Belt Roll Diameter (mm)	3000	3500	3500	3500
成型带坯最大重量 (t) Max. Forming Belt Weight (t)	10	10	10	10
成型的最大速度 (m/min) Max. Forming Speed (m/min)	5-30	5-30	5-30	5-30
适用胶片的最大厚度 (mm) Applicable Max. Rubber Sheet Thickness (mm)	1-20	1-20	1-20	1-20
张力控制方式 Tension Control Method	张力控制器 Tension Controller	张力控制器 Tension Controller	张力控制器 Tension Controller	张力控制器 Tension Controller
纠偏控制系统 Deviation Correction System	伺服 Servo	伺服 Servo	伺服 Servo	伺服 Servo
成型桌面长度 (mm) Forming Table Length (mm)	3000	3000	3000	3000
成型桌面高度 (mm) Forming Table Height (mm)	820	820	820	820

产品适用领域/ Product Application Fields

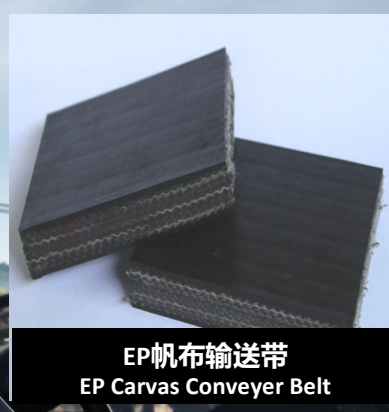

备注：1. 以上规格公司保留变更权，如因设计变更时，恕不另行通知。
2. 如有非标准规格，可依据客户需求设计与制造。

Notes: 1. The company reserves the right to modify the specifications above without prior notice in case of design changes.
2. For non-standard specifications, design and manufacturing can be carried out based on customer requirements.

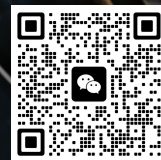

扫码咨询
Scan to consult



业务覆盖

Business Coverage



全球 26+ 国家
Over 26 Countries globally



全球 50+ 客户/代理商
Over 50 customers/agents worldwide



扫码观看
企业全景

Scan the QR code
for a panoramic view
of the enterprise



全国 200+ 客户

Over 200 customers nationwide



全国 300+ 合作商

Over 300 cooperative partners nationwide

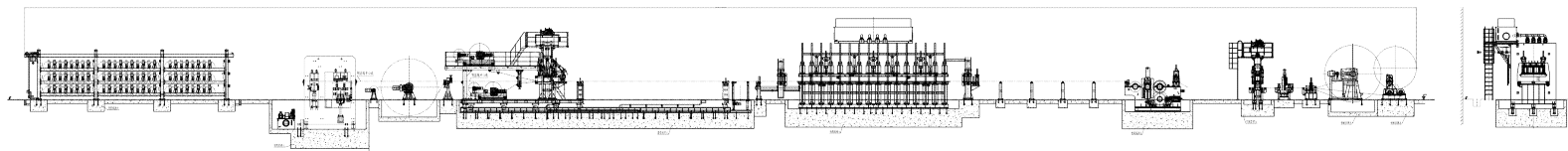

联系我们 | Contact Us

邮箱 | E-Mail: sales@hh-hz.com

手机 | Cell Phone: 155-4265-6399

邮编 | Zip Code: 116400

WhatsApp: 15142420383

地址 | Address: 中国辽宁省大连市庄河市三环大街219号

No. 219, Sanhuan Street. Thuinghe City, Dalian City, Liaoning Province. China



中国官网
Chinese Website



国际官网
Global Website



官方微信
Company Wechat